

10 GA OUTER TANK
10 GA INNER TANK

ITEM	SIZE	FUNCTION
A	2"	PRIMARY WORKING VENT
B	4"	PRIMARY TANK EMERGENCY VENT (PVC PLUG)
C	10"	HATCH WITH SCREEN
D	2"	MECHANICAL GAUGE
E	2"	DROP PIPE WITH DISCONNECT
F	4"	SECONDARY CONTAINMENT EMERGENCY VENT (PVC PLUG)
G	2"	SECONDARY CONTAINMENT WORKING VENT
H	2"	SPARE PVC PLUG
I	2"	FLIP CAP

NOTE: ALL CASTERS WILL BE SWIVEL WITH LOCKS
NOTE: TESTED TO STANDARD UL 142

*** This Drawing is the property of Onken Inc, DO NOT COPY**

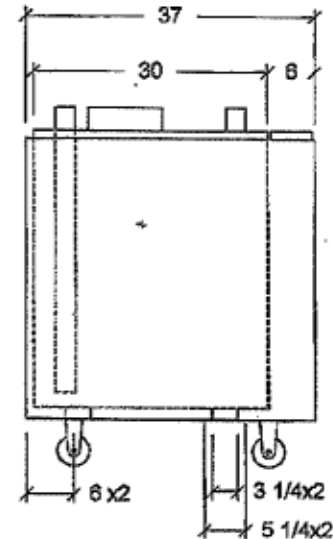
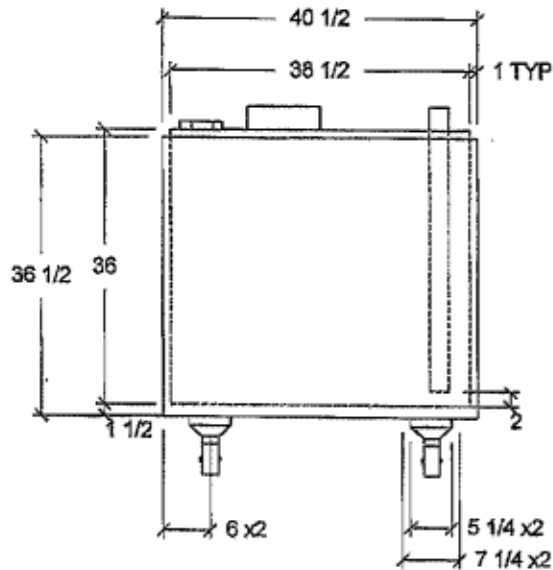

ONKEN'S INC Model #2235	
185 GAL DOUBLE WALL OIL TANK	06/25/12